



**INSTALLATION**  
and  
**TECHNICAL GUIDE**

Note: This document supersedes all printed and electronic Installation and Technical Guides previously distributed for Metroflor®.

## IMPORTANT NOTES

**MOISTURE:** Metroflor® Corp. recommends all concrete subfloors (new and old) be tested using Calcium Chloride Test ASTM F1869 or Relative Humidity Test ASTM F 2170. New concrete slabs must cure for a minimum of 90 days. Even existing concrete slabs can have moisture problems. Never install Artistek® Floors where surface or subfloor moisture is present. Excessive moisture will cause failure. The installer is responsible for conducting a moisture test several days prior to installation to be sure that moisture is at recommended levels, since moisture will directly affect the cure, set and bond of adhesives. See adhesive pail for details. Electronic meter testing is not considered a replacement for a Calcium Chloride Test or Relative Humidity Test.

**pH LEVELS:** Perform pH tests before installing Artistek® Floors. Follow the Prevail™ adhesive instructions located on the label for further information.

**PRODUCT ACCLIMATION:** The HVAC system should be operating at least one week before installation. Artistek® Floors, Prevail™ adhesive, and the subfloor must be acclimated at a temperature between 65° and 85°F for 48 hours before, during and after installation. Do not open Artistek® Floors cartons during acclimation. Spread the cartons no more than three high and at least 4 inches apart, positioning them away from heating and cooling ducts and direct sunlight. After installation, maintain a constant room temperature between 55° and 85°F. These guidelines have been set in order to prevent excessive expansion and contraction of the product after installation.

## ATTENTION

If Artistek® Floors luxury resilient tile and plank will be combined in a single installation, the products must be the same gauge and edge treatment. Carefully inspect Artistek® Floors luxury resilient tile and plank for visual defects prior to beginning the installation. Do not install Artistek® Floors with damage, visual defects or severe color variations.

**Metroflor® Grab-Tak Tiles are NOT WARRANTED for use over radiant heat floors.**

Metroflor® Grab-Tak Tiles do not require additional adhesive. With the exception of recommendations for radiant heat floors and adhesive use and application, the installation instructions outlined in this guide apply to Metroflor® Grab-Tak Tiles.

## WARNING

Various Federal, State and Local government agencies have regulations governing the removal of in-place asbestos-containing material. If you contemplate the removal of a resilient floor covering structure that contains (or is presumed to contain) asbestos, you must review and comply with all applicable regulations. Do not sand, dry sweep, dry scrape, drill, saw, bead blast, or mechanically chip or pulverize existing resilient flooring, backing, lining felt, asphalt "cut-back" adhesive, or other adhesive. These products may contain asbestos fibers and/or crystalline silica. Avoid creating dust. Inhalation of such dust is a cancer and respiratory tract hazard. Smoking by individuals exposed to asbestos fibers greatly increases the risk of bodily harm. Unless positively certain that the product is a non-asbestos containing material, you must presume it contains asbestos. Regulations may require that the material be tested to determine asbestos content. RFCI™'s Recommended Work Practices for Removal of Resilient Floor Covering are a defined set of instructions addressed to the task of removing all resilient floor covering structures. For further information, contact the Resilient Floor Covering Institute website at [www.rfci.com](http://www.rfci.com).

## SUBFLOOR and INSTALLATION REQUIREMENTS

### Approved Subfloors

- A. **CONCRETE:** Concrete substrates must be clean and dry, smooth, and structurally sound. They must be free of dust, dirt, paint, varnish, oil, grease, solvent, wax, existing adhesives and other extraneous material including curing and parting compounds, sealers and surface hardeners that may interfere with the adhesive bond. Do not use on chemically cleaned substrates or those treated with silicate compounds. Even after old glued-down carpet has been removed and the subfloor has been scraped, it should not be assumed that the concrete is porous. Often, the old adhesive has sealed the floor. Be aware that porous subfloors may require a different trowel size for adhesive application than non-porous subfloors. See Prevail™ adhesive pail label for trowel size recommendations. If oil, grease or other contaminants have deeply penetrated the concrete and cannot be thoroughly removed, Artistek® Floors cannot be installed. If latex liquid has been used to seal off old cutback adhesives, the concrete should be considered non-porous. All concrete must have compression strength of 3,500 psi or greater.
- B. **LIGHTWEIGHT CONCRETE:** The minimum density of the concrete should be greater than 90 lbs per cubic foot. The minimum compressive strength should be 2,500 psi or greater. Gypsum-based concretes are not recommended. If installing over gypsum or other forms of lightweight underlayment, apply an acrylic based primer-sealer coat before troweling or rolling on the adhesive as specified by the underlayment manufacturer.
- C. **WOOD SUBFLOORS:** Should be standard double-layer construction, with a finished thickness of at least 1" and should have 18" of well-ventilated air space underneath. Crawl spaces should be insulated and protected by a vapor barrier. Do not install vinyl flooring over a sleeper type subfloor, or over plywood that is directly over a concrete slab. All wood subfloors must meet national and local building code guidelines.
- 1) **PLYWOOD:** Use only American Plywood Association (APA) underlayment grade plywood, minimum ¼" thickness. Allow expansion spacing between plywood butt joints of 1/32"-1/16". When installing underlayment, stagger cross-joints 4' on an 8' panel (minimum 16"), lightly butt the panels, and set fasteners flush or slightly below the surface level of the underlayment. Fill underlayment seams, nail holes and any indentations with an approved Portland Cement-type floor patch, allow recommended drying time, and sand the patch smooth. All dust must be COMPLETELY removed to ensure a strong adhesive bond. Vacuum or sweep thoroughly, then apply adhesive. Manufacturer-certified poplar, birch and spruce plywood underlayment, with a fully sanded face and exterior glue can also be used.
  - 2) **LAUAN PLYWOOD:** Use only Type 1 lauan exterior grade "BB" or "CC" for underlayment. The use of lesser grades of lauan plywood is unacceptable and may cause severe problems including discoloration, indentation, loss of bond and delamination when used as an underlayment.  
*NOTE: The use of underlayments such as lauan and other extremely porous wood or particleboard underlayments will reduce the flash and working time of adhesives. It is best to apply an acrylic-based primer-sealer to any porous underlayment prior to installing Artistek® Floors. A manufacturer's certification of lauan grade must accompany any claim involving the use of a lauan underlayment.*
- D. **RADIANT HEAT:** Radiant heat components must be cast at least 1/2" below the concrete slab. The heating system must operate for at least two weeks prior to installation. Radiant heat floors should be turned off 3 days prior to installation and remain off for at least 6 days after installation to allow the adhesive to fully cure. After 6 days, turn the radiant heating system back on beginning at 65° F, and gradually increase the temperature every 24 hours in 5° increments to a maximum operating temperature 85° F. Consult the radiant heat system manufacturer for further information.
- E. **QUARRY TILE, TERRAZZO and CERAMIC TILE:** Skim coat grout lines with embossing floor leveler. Fill in dips and voids with cementitious leveling compounds to level the subfloor.

### Non-Approved Subfloors

Non-approved subfloors include, but are not limited to: Oriented strand board (OSB), particleboard, hardboard, treated plywood, strip wood floors, chipboard, waferboard, Masonite, knotty plywood, glass mesh tile boards, cementitious tile backer boards, fire-retardant or preservative-treated plywood, asphalt tile, rubber tile, self-stick tile. NOTE: Any appearance or performance-related issues associated with the underlayment are the responsibility of the installer and/or underlayment manufacturer.

## SUBFLOOR PREPARATION

**CONCRETE SLABS:** *NOTE: All concrete, whether new or old, must be tested for moisture using either the calcium chloride test or a test for relative humidity. Concrete should also be tested for pH, porosity and bond prior to installing Artistek® Floors.* The installer is responsible for performing moisture tests. Moisture will retard and prevent adhesive from setting, resulting in installation failure. See Prevail™ adhesive pail labels for details. New concrete should cure under well-ventilated conditions for at least 90 days and must be tested for moisture and pH before installing Artistek® Floors. Do not install if excessive moisture, hydrostatic pressure, or alkaline conditions are evident. Concrete substrates must be clean and dry, smooth, and structurally sound. They must be free of dust, dirt, paint, varnish, oil, grease, solvent, wax, existing adhesives and other extraneous material including curing and parting compounds, sealers and surface hardeners that may interfere with the adhesive bond. Remove any curing agents from concrete surfaces. Level any high spots and fill in all cracks, holes and minor depressions with a Portland Cement-based filler, then sand smooth. Installation failures due to the above issues are not the responsibility of Metroflor® Corp. and warranties will not apply. Whenever questionable surfaces are involved, Metroflor® Corp. recommends a bond test as described later in this section.

**PATCHING & LEVELING:** Use only Portland-Cement based patching and leveling compounds. Allow at least 24 hours for underlayment drying before installing Artistek® Floors. Self-leveling underlayments may have very high moisture content requiring longer curing times, up to 10 days. Check with a moisture meter before starting installation. *Note: Adding latex to levelers will normally make the floor NON-POROUS. Test for porosity and follow non-porous adhesive recommendations if necessary.* Follow the manufacturer's instructions, and do not over-water underlayments. The installer is responsible for observing cure times, moisture content, adhesive bonding and the structural integrity of any leveling or patch compound used.

**EMBOSSING LEVELERS:** Embossing levelers are for use on sheet goods with textures that could telegraph through Artistek® Floors. If self-leveling underlayments are used they must fully cure before installing Artistek® Floors. Test self-leveling compounds for moisture before installing. The installer is fully responsible for moisture and leveler-related issues. *Note: The use of levelers on sheet goods will not create a porous subfloor.*

**SEALERS:** Metroflor® Corp. does not endorse the use of any concrete or floor sealers against moisture. If moisture is present, **DO NOT INSTALL** Artistek® Floors. Encapsulator compounds will protect the installation against alkalinity. Some also serve as a barrier between old and new adhesives to deaden old adhesive tack, prevent plasticizer migration and seal over dust and old adhesive residues, including cutback. Most latex and acrylic-based encapsulator compounds are compatible with Prevail™ adhesives. Existing adhesives must be mechanically scraped down to a bare minimum residue flat with the substrate before applying the encapsulator compound. Apply the compound evenly across the entire surface of the floor according to the manufacturer's instructions. There must be no gaps in the application. Allow to dry completely before applying new adhesives.

*NOTE: Metroflor® Corp. warrants Artistek® Floors and Prevail™ adhesives to be free from defects. The condition of the subfloor and adhesion problems resulting from the use of non-recommended, improper, or incorrectly prepared sealers, embossing levelers, patches, concrete, gypsum-based products and other such items, are the sole responsibility of the installer and/or manufacturer of the particular sub-flooring product.*

**ADHESIVE BOND TEST:** Use the following test to determine if a subfloor is compatible for use with Prevail™ adhesives, or to determine if the porous or non-porous adhesive application method is required: Using the flooring and adhesive suitable for the subfloor, install a 3" x 3" section following the recommended installation procedures. Tape the edges with duct tape to prevent the adhesive from drying prematurely. Select light traffic areas such as those located next to walls or columns. After 48 hours, the adhesive should be dry and the flooring should be difficult to remove. *Note: the adhesive is dry at this point, but not cured.* Full cure and maximum bond will not occur for 6-8 days. On large installations, tests should be performed every 50 linear feet. Bond testing may take some time to complete, but the cost and time involved in a floor failure are considerably more.

## TILE INSTALLATION 12" X 12", 12" X 24", 16" X 16", 16" X 32" and 18" X 18"

### Layout of the Room for Squarely Laid Fields

To square the area to be covered, first find the center of one end of the main rectangle. Locate the same point at the other end wall. Snap a chalk line between these points to mark the center line on the floor. Then measure along this center line to find the middle of the room.

Figure 1

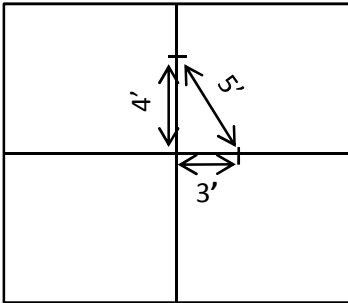

At the center point, mark off a line across the room at exactly right angles to the first line. This may be accomplished using the 3-4-5 triangle method. **(See Figure 1)** Starting from the center point, make a mark measuring 4 feet vertically and 3 feet horizontally. Connect the marks with a diagonal line to complete the triangle. If the diagonal line does not measure exactly 5 feet, the center crossing lines are not at a true right angle. For large rooms, multiples of the above dimensions may be used to obtain greater accuracy. (6-8-10, 9-12-15, and so on.) Dry-lay a row of tiles from the center line to the side wall to determine the space left for the borders. If the resulting border is too small, move the starting point over a half tile width so that it straddles the center line. Repeat the same procedure lengthwise of the room. (This can readily be figured out from the room dimensions without putting down the tiles if desired.)

Figure 2

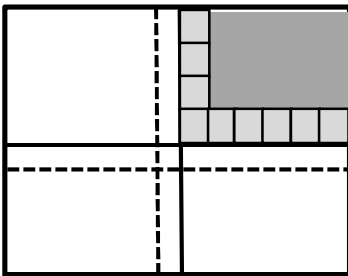

If the center row of tiles straddles one or both center lines, additional guidelines should be snapped on the floor one-half tiles' width on either one or both center lines, as required. **(See Figure 2)**

Figure 3

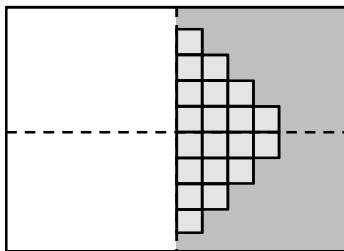

After the border widths have been determined and the center starting lines have been snapped, spread the recommended adhesive on the center lines leaving portions of the lines at center and near each wall uncovered. **(See Figure 3)**

Apply adhesive as recommended on the label. Do not apply more adhesive than can be worked, following the adhesive manufacturer's recommendations. Lay the tiles from the center of the room, working towards the walls as shown.

**IMPORTANT:** All flooring must be rolled with a minimum 100-lb roller after installation. Use a hand roller in areas not reached with a 100-lb. roller.

## PLANK INSTALLATION 3" X 36", 4" X 36", 6" X 36", 6" X 48" and 9" X 36"

Figure A

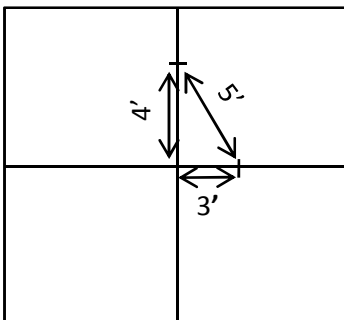

At the center point, mark off a line across the room at exactly right angles to the first line. This may be accomplished using the 3-4-5 triangle method. **(See Figure A)** Starting from the center point, make a mark measuring 4 feet vertically and 3 feet horizontally. Connect the marks with a diagonal line to complete the triangle. If the diagonal line does not measure exactly 5 feet, the center crossing lines are not at a true right angle. For large rooms, multiples of the above dimensions may be used to obtain greater accuracy. (6-8-10, 9-12-15, and so on.)

**Figure B**

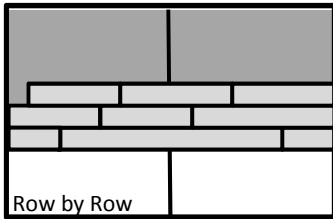

Spread the adhesive over one-half the area and after it is ready, start laying the planks from the right angle formed in the center of the room by center lines. Carefully place the first piece of plank at the junction of the chalk lines. Continue to lay the plank, making sure each plank is flush against the chalk line and tight against the adjoining plank. Make sure the plank is well seated into the adhesive paying special attention, to the edges. Lay row-by-row, or pyramid fashion, as shown. (See Figures B & C)

**Figure C**

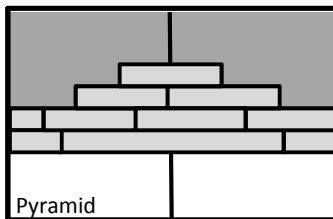

Lay the material from the center of the room, working towards the walls as shown. It is imperative that the first row is placed precisely and accurately against the reference line as you begin installation. Position planks without sliding them through the adhesive.

**IMPORTANT:** All flooring must be rolled with a minimum 100-lb roller after installation. Use a hand roller in areas not reached with a 100-lb. roller.

**Note:** All warranties and guarantees pertaining to the suitability and performance of any product not recommended by Metroflor® Corp. rests with the material manufacturer or the installation contractor and NOT with Metroflor® Corp.

To register and activate your product warranty, please visit [www.artistekfloor.com](http://www.artistekfloor.com) and click on the Warranty/Maintenance tab. The registration information you provide will be used only to register your purchase and for no other purpose.

For further information, inquiries and troubleshooting please contact:

**Metroflor® Corp.**  
**119 Thomas Street**  
**Calhoun GA 30701**  
**888-235-6672**  
**[www.Metroflorcorp.com](http://www.Metroflorcorp.com)**

Appendix

# PREVAIL™ ADHESIVE RECOMMENDATIONS

Prevail Product	Adhesive Type	Usage	PH Tolerance	PH Limits	Spread Rate (Porous)	Spread Rate (Non-Porous)	LEED Qualified	FloorScore Certified	Commercially Rated	Residentially Rated	Phased	Concrete	Radiant Floors
PR-30-GS	Cyanoacrylate	Grip Strip Adhesive	N/A	N/A	150 sf per tube	150 sf per tube	NO	NO	✓	✓	✓	✓	✓
PR-100-U	Acrylic	Hard-Set Double Glue Down over Prevail™ Pad	10	80%	900 sf-rolled per 4 gal pail	900 sf-rolled per 4 gal pail	YES	NO	✓	✓	✓	✓	✓
PR-2000	PSA	Modular Carpet Tile	9	80%	100-100 sf of troweled per gal	350-400 sf rolled per gal 220; 200 sf troweled per gal	YES	YES	✓	✓	✓	✓	✓
PR-3100	Spray Acrylic	Sheet, LVT, Modular Carpet Tile	10	80%	140-160 sf per 22 oz can	150-200 sf per 22 oz can	YES	YES	✓	✓	✓	✓	✓
PR-3500	Wet Set	LVT	9	80%	100-125 sf per gal	150-150 sf per gal	YES	YES	✓	✓	✓	✓	✓
PR-4000	2-Part Epoxy	Sheet, LVT	9	75%	130-150 sf per gal	130-150 sf per gal	YES	YES	✓	✓	✓	✓	✓
PR-4500	Premium PSA	LVT	10	87%	180-200 sf per gal	220-260 sf per gal	YES	YES	✓	✓	✓	✓	✓
PR-5000	PSA	LVT	9	75%	100-125 sf per gal	150-180 sf per gal	YES	YES	✓	✓	✓	✓	✓
PR-6000	PSA	Sheet, LVT	10	85%	150-180 sf per gal	200-220 sf per gal	YES	YES	✓	✓	✓	✓	✓

1 year Shelf Life on ALL Adhesives in Unopened Properly Stored Containers

## PREVAIL™ FLOORCARE PRODUCTS

Product	UPC	Item #	Usage
Prevail™ Neutral Cleaner	088969701275 (qt) 088969701282 (gal)	PR-VICL-QT PR-VICL-GL	A concentrated cleaner for maintaining all Metroflor® vinyl products and finishes.
Prevail™ RTU Neutral Cleaner	088969701640 (22 oz)	PR-RTU-22	A ready-to-use cleaner for maintaining all Metroflor® vinyl products and finishes.
Prevail™ Matte Finish	088969701251 (qt) 088969701268 (gal)	PR-MAFN-QT PR-MAFN-GL	Apply to Artistek® Floors to protect and renew the look of the flooring.
Prevail™ Gloss Finish	088969701237 (qt) 088969701244 (gal)	PR-GLFN-QT PR-GLFN-GL	Apply to Artistek® Floors to protect and renew the look of the flooring.
Prevail™ Vinyl Stripper	088969701299 (qt)	PR-VIST-QT	Concentrated stripper. Removes most detergent-resistant waxes and acrylic finishes.
Prevail™ Black Scuff & Adhesive Remover	088969701305 (22 oz)	PR-BSAR-22	Emulsifies adhesives, removes black scuffs and soil. Effective on grease, crayon, and lipstick.
Prevail™ Scratch Remover	088969701336 (22 oz)	PR-KSR-22	Conceals surface scratches and micro hazing caused by fine particle abrasion on vinyl flooring. Reduces the visibility of scratches under furniture, near entrances and other high traffic areas.

Visit [www.Metroflorprevail.com](http://www.Metroflorprevail.com)  
for more information about  
the entire PREVAIL™ line  
of adhesives and accessories.